

B.Tech. DEGREE EXAMINATION, DECEMBER 2008.

(Examination at the end of First Year)

Paper I — MATHEMATICS — I

**Time : Three hours
75 marks**

Maximum :

Answer Question No. 1 compulsorily and ONE question from each Unit.

All questions carry equal marks.

1. (a) Find the order and degree of the differential equation $y = x \frac{dy}{dx} + \frac{x}{dy/dx}$.
- (b) Define Leibnitz's linear equation.
- (c) When do you say that two family of curves are orthogonal.
- (d) Find the complementary function of
- $$\frac{d^2 y}{dx^2} - y = e^{3x} \cos 2x.$$
- (e) State the Legendre linear equation.
- (f) Define the coefficient of correlation.
- (g) What are the applications of normal distribution.
- (h) Find $L \left\{ \frac{\sin at}{at} \right\}$.
- (i) Write the shifting property for inverse Laplace transform.
- (j) Find $L^{-1} \left\{ \frac{1}{s^2 + a^2} \right\}$.
- (k) Define unit step function.
- (l) If $z = (x^2 + y^2 + z^2)^{-1/2}$, then find $\frac{d^2 z}{dx^2}$.
- (m) Solve $\frac{\partial^2 z}{\partial x \partial y} = \frac{x}{y} + a$.
- (n) Solve $\sqrt{p} + \sqrt{q} = 1$.
- (o) Define non-homogeneous linear partial differential equations.

UNIT I

2. (a) Solve

$$xy(1 + xy^2) \frac{dy}{dx} = 1.$$

(b) Solve

$$(y - px)(p - 1) = p.$$

Or

3. (a) Find the curve for which the normal makes equal angles with the radius vector and the initial line.

(b) Solve

$$\frac{d^2y}{dx^2} - 2 \frac{dy}{dx} + y = xe^x \sin x.$$

UNIT II

4. (a) Using the method of variation of parameters, solve $y'' - 2y' + y = e^x \log x$.

(b) Solve

$$\frac{dy}{dt} + 2x + 3y = 0, 3x + \frac{dy}{dt} + 2y = 2e^{2t}.$$

Or

5. (a) The mean and the standard deviation of a normal distribution are 75 and 15 respectively. If 149 of the observations lie between $X = 60$ and $X = 81$ what is the population of the whole distribution.

(b) Find the correlation coefficient between x and y for the given value. Find also the two regression lines

x	1	2	3	4	5	6	7	8	9	10
y	10	12	16	28	25	36	41	49	40	50

UNIT III

6. (a) Find the Laplace transform of $\frac{1 - \cos 2t}{t}$.

(b) Find the inverse Laplace transform of $\frac{1 + 2s}{(s + 2)^2 (s - 1)^2}$.

Or

7. (a) Apply convolution theorem to evaluate

$$L^{-1} \left\{ \frac{s^2}{(s^2 + a^2)(s^2 + b^2)} \right\}.$$

(b) Use transform method to solve

$$\frac{d^3y}{dt^3} + 2 \frac{d^2y}{dt^2} - \frac{dy}{dt} - 2y = 0 \text{ where } y = 1, \frac{d^2y}{dt^2} = 2, \frac{dy}{dt} = 2, \text{ at } t = 0.$$

UNIT IV

8. (a) Solve

$$x(y^2 - z^2)P + y(z^2 - x^2)Q - z(x^2 - y^2)R = 0.$$

(b) Solve

$$z^2(p^2 + q^2) = x^2 + y^2.$$

Or

9. (a) Solve

$$\frac{\partial^2 z}{\partial x^2} + \frac{\partial^2 z}{\partial x \partial y} - 6 \frac{\partial^2 z}{\partial y^2} = y \cos x.$$

- (b) Solve

$$(D - D' - 1)(D - D' - 2)z = e^{2x - y}.$$

wk 7

(DE 102)

B.Tech. DEGREE EXAMINATION, DECEMBER 2008.

(Examination at the end of First Year)

Paper II — MATHEMATICS — II

Time : Three hours

Maximum : 75 marks

Answer question No. 1 compulsorily and ONE question from each Unit.

1. (a) Define unit matrix.
(b) Define rank of a matrix.
(c) Find the eigen values of the matrix $\begin{bmatrix} 5 & 4 \\ 1 & 2 \end{bmatrix}$.
(d) Define Skew-Hermitian matrix.
(e) State Lagrange's mean value theorem.
(f) Write the Maclaurin's expansion of $\sinh \theta$.
(g) Evaluate $\lim_{x \rightarrow 0} \left(\frac{1}{\sin x} - \frac{1}{x} \right)$.
(h) Define circle of curvature.
(i) Evaluate $\int_0^b dy \int_0^{a\sqrt{(1-y^2)/b^2}} dx$.
(j) State the theorem of perpendicular axis.
(k) Define gamma function.
(l) Find ∇f at the point $(2, -1, 1)$, when $f = xy^2 + yz^3$.
(m) Show that $\text{curl grad } f = 0$.
(n) Evaluate $\int_{t=2}^{t=4} \vec{F}(t) dt$, where $\vec{F}(t) = (5t^2 - 3t)\vec{i} + 6t^3\vec{j} - 7t\vec{k}$.
(o) State Stoke's theorem.

UNIT I

2. (a) Find the inverse of $A = \begin{bmatrix} 3 & -3 & 4 \\ 2 & -3 & 4 \\ 0 & -1 & 1 \end{bmatrix}$ and show that $A^3 = A^{-1}$.

(b) Solve the system of equations $x + y + z = 3$, $x + 2y + 3z = 4$, $2x + 3y + 4z = 7$ by matrix method.

Or

3. (a) Verify that the matrix $\begin{bmatrix} \cos \theta & 0 & \sin \theta \\ 0 & 1 & 0 \\ \sin \theta & 0 & \cos \theta \end{bmatrix}$ is orthogonal.

(b) Find the eigen values and eigen vectors of the matrix $\begin{bmatrix} 6 & -2 & 2 \\ -2 & 3 & -1 \\ 2 & -1 & 3 \end{bmatrix}$.

UNIT II

4. (a) Verify Rolle's theorem for $y = e^x(\sin x - \cos x)$ in $\left(\frac{\pi}{4}, \frac{5\pi}{4}\right)$.

(b) Use Maclaurin's series, expand $\tan x$ upto the term containing x^5 .

Or

5. (a) Find the equation of the tangent at any point (x, y) to the curve $x^{\frac{2}{3}} + y^{\frac{2}{3}} = a^{\frac{2}{3}}$. Show that the portion of the tangent intercepted between the axes is of constant length.

(b) Find the coordinates of the centre of curvature at $(at^2, 2at)$ on the parabola $y^2 = 4ax$.

UNIT III

6. (a) By changing the order of integration, evaluate

$$\int_0^3 \int_1^{\sqrt{4-y}} (x+y) dx dy.$$

(b) Calculate the area included between the curve $r = a(\sec \theta + \cos \theta)$ and its asymptote.

Or

7. (a) Find the volume of the portion of the sphere $x^2 + y^2 + z^2 = a^2$ lying inside the cylinder $x^2 + y^2 = ax$.

(b) Prove that

$$\int_0^1 \frac{x dx}{\sqrt{1-x^5}} = \frac{1}{5} \beta\left(\frac{2}{5}, \frac{1}{2}\right).$$

UNIT IV

8. (a) Find the angle between the surfaces $x^2 + y^2 + z^2 = 9$ and $z = x^2 + y^2 - 3$ at $(2, -1, 2)$.

(b) Prove that

$$\begin{aligned} \nabla(\bar{F} \cdot \bar{G}) &= (\bar{F} \cdot \nabla)\bar{G} + (\bar{G} \cdot \nabla)\bar{F} + \bar{F} \times (\nabla \times \bar{G}) + \bar{G} \times (\nabla \times \bar{F}). \end{aligned}$$

Or

9. Evaluate $\int_S \vec{F} \cdot \vec{N} ds$ where $\vec{F} = 6z\vec{i} - 4\vec{j} + y\vec{k}$ and S is the portion of the plane $2x + 3y + 6z = 12$ in first octant.

(DE 103)

B.Tech. DEGREE EXAMINATION, DECEMBER 2008.

(Examination at the end of First Year)

Paper III — PHYSICS

Time : Three hours

Maximum : 75 marks

Answer ALL FIVE questions.

All questions carry equal marks.

Answer question No. 1 compulsorily and ONE question from each Unit.

(1 × 15 = 15)

1. (a) Explain the generation of ultrasonic waves by piezoelectric method.
- (b) Obtain the resolving power of a grating.
- (c) Explain Hall effect and its used.
- (d) Explain Compton effect
- (e) Explain the working of Ga-As laser.
- (f) Write a note on high temperature super conductors.

UNIT I — (15 marks)

2. (a) Explain the formation of Newton's rings in reflected light and obtain the conditions for maxima and minima.
- (b) Give the theory of diffraction by a plane transmission grating.

Or

- (c) Explain the principle of double refraction and show how polarized light can be obtained using double refraction.
- (d) How do you determine the specific rotary power of an optically active solution using optical activity?

Calculate the thickness of the quarter wave plate when the wave length of light is equal to 5890\AA and $\mu_o = 1.55$ and $\mu_e = 1.54$.

UNIT II — (15 marks)

3. (a) State and explain Gauss law. Obtain an expression for the potential due to a charged disc.

(b) Explain Faraday's laws of electromagnetic induction. In a spark coil of 1000 turns the magnetic flux changes from 0.75 W to zero 0.02 seconds. Calculate the emf produced in the coil.

Or

(c) Explain Maxwell's equations in differential form. What is the significance of the displacement current term?

(d) Give a brief account of electromagnetic oscillations of LC circuits and obtain an expression for the frequency of oscillation.

UNIT III — (15 marks)

4. (a) Give the important features of black body radiation. Explain the quantum nature of radiation.

(b) Describe the Davisson and Germer experiment for electron waves and mention its important results.

Or

(c) Draw the sketch of a GM counter and explain its working.

(d) Explain the nature of Fermi level in p-type and n-type semiconductors.

(e) Explain Fermi-Dirac distribution function.

UNIT IV — (15 marks)

5. (a) Explain propagation of light in a step index fibre and obtain an expression for its numerical aperture.

(b) Differentiate between holography and photography. Mention some applications of holography.

(c) Explain Meissner effect in superconductors.

Or

(d) Explain the working of LED and LCD and give their applications.

(e) Explain the design of a solar cell and explain its operation. Obtain an expression for its efficiency.

(DE 104)

B.Tech. DEGREE EXAMINATION, DECEMBER 2008.

(Examination at the end of First Year)

Paper IV — CHEMISTRY

Time : Three hours

Maximum : 75 marks

Answer Question No. 1 compulsorily and ONE question from each Unit.

Each question carries 15 marks.

1. (a) Explain the WHO standards of water.
- (b) Explain sedimentation.
- (c) What is coordination number?
- (d) What is electro dialysis?
- (e) What is Bragg's equation?
- (f) Explain the difference between conductors and semiconductors.
- (g) What is a polymer?
- (h) What is polyurethane rubber?
- (i) What is electrochemical series and its importance?
- (j) What is modern lithium battery?
- (k) What is fuel cell?
- (l) What is corrosion?
- (m) Explain what is electroplating.
- (n) Explain the cellular material used in information technology.
- (o) Explain what is inter granular corrosion.

UNIT I

2. (a) Explain with a neat diagram of "lime-soda" process and demineralization.
- (b) Write short notes on hardness of water.

Or

- (c) Explain the purification of water for municipal supply.
- (d) A sample of water from Guntur has been found to contain has following in ppm.

Ca (HCO₃)₂ = 9.72 Mg (HCO₃)₂ = 11.68 Ca SO₄ = 13.60 Mg SO₄ = 16.80. Calculate the temporary, permanent and total hardness of water. (Atomic weights : Ca = 40, Mg = 24, C = 12, S = 32, O = 16, H = 1).

UNIT II

3. (a) Write short notes on types of crystals and point defects.
- (b) Explain the main features of band theory of solids.

Or

- (c) Write short notes on polymers definition and classifications.
- (d) Write short notes on condensation polymerization and addition polymerization.

UNIT III

4. (a) Explain a method for the determination of pH using glass electrode.
(b) Explain what is reference electrode. Mention the uses of reference electrode.

Or

- (c) Explain the electrochemistry of the three most common battery systems. Advantages and applications.

UNIT IV

5. (a) Explain the electrochemical theory of corrosion.
(b) Explain the types of corrosion in detail.

Or

- (c) Explain the following materials used in Information Technology (IT).
(i) Iron sulphide
(ii) Zinc oxide and
(iii) Cadmium sulphide.
(d) Write short notes on the electroplating for protection of corrosion.

(DE 105)

B.Tech. DEGREE EXAMINATION, DECEMBER 2008.

(Examination at the end of First Year)

Paper V — ENGLISH

Time : Three hours

Maximum : 75 marks

1. Correct the errors in the following sentences : (15 × 1 = 15)
- (a) Each of those boys play tennis.
(b) He is a liar and a cheater.
(c) He is older than me.
(d) Of the two, this is the best.
(e) Sky is clear today.
(f) Cow is an useful animal.
(g) This book is too interesting.
(h) He regretted for his mistake.
(i) The man died from Malaria.

- (j) He is fond to play.
- (k) The teacher asked a question to Rama.
- (l) We will be missing you badly.
- (m) This pen costed fifteen rupees.
- (n) She has two brother-in-laws.
- (o) I have read a novel yesterday.

2. (a) Read the following passage and answer the questions given below : (5 × 2 = 10)

Science and technology are the most important development of this century. They have done a lot to change the face of the world. However, if science does not lead to peace it would mean a great disaster for us. Science has developed and should develop with a view to helping the people to find a better life, a happier one and more peaceful one also. And if science leads to the making of nuclear bombs or atom bombs the very purpose and objective of science would come to naught. With the help of science we have to obliterate the differences which exist between one community and the other and between one country and the other. The world could not remain divided into a developed area and an undeveloped area, or a few countries highly developed and other countries still in a developing stage. This gulf, this difference has to be wiped out and science could be of immense help in this direction.

- (i) What should be the main goal of science and technology?
- (ii) What will be the result of making a nuclear bomb?
- (iii) What role does science play in the relationships between the countries?
- (iv) Why does some countries lag behind the others in progressing?
- (v) Give a suitable title to the above passage.

(b) Bring out the differences of meaning of any FIVE of the following pairs of words and use them in sentences of your own : (5 × 1 = 5)

- (i) Adverse – Averse
- (ii) Allusion – Illusion
- (iii) Avert – Invert
- (iv) Altar – Alter
- (v) Cast – Caste
- (vi) Decease – Disease
- (vii) Duel – Dual
- (viii) Excess – Access
- (ix) Pray – Prey
- (x) Wave – Waive

3. (a) Write a paragraph on any ONE of the following : (1 × 6 = 6)

- (i) Computers and Progress

(ii) National Integration.

(b) (i) Write a letter to the police officer of your town complaining him against disturbance in your street. ($1 \times 5 = 5$)

Or

(ii) Write a letter to your friend requesting him to come to your village during the summer vacations.

(c) Give the meaning and use of them in your own sentences any EIGHT of the idiomatic expressions following : ($8 \times \frac{1}{2} = 4$)

(i) break down

(ii) get over

(iii) look down

(iv) stand for

(v) take after

(vi) wash one's dirty linen in public.

(vii) cold blood

(viii) at his fingers end

(ix) a fish out of waters

(x) cock and bull story.

4. (a) Write a brief report of on literary meeting held in your college. ($1 \times 10 = 10$)

(b) Give one word substitutions for the explanations given below : ($10 \times \frac{1}{2} = 5$)

(i) An unmarried man.

(ii) Custom of having many wives.

(iii) Disbeliever in god.

(iv) One who eats everything.

(v) One who hates the mankind.

(vi) The murder of a human being.

(vii) Animal that can live on land and water.

(viii) A place where birds are kept.

(ix) An insect with many legs.

(x) Study of insects.

5. (a) Write a small essay on any ONE of the following : ($1 \times 5 = 5$)

(i) Globalization

(ii) Science and Religion.

(b) Expand any ONE of the following : ($1 \times 5 = 5$)

- (i) All that glitters is not gold.
- (ii) Slow and steady, wins the race.
- (c) Write the antonyms to the following : (5 × $\frac{1}{2}$ = 2 $\frac{1}{2}$)
- (i) Brief
- (ii) Kind
- (iii) Praise
- (iv) Late
- (v) Courage.
- (d) Write synonyms for the following : (5 × $\frac{1}{2}$ = 2 $\frac{1}{2}$)
- (i) danger
- (ii) quote
- (iii) greed
- (iv) mad
- (v) wise.
-

(DE 106)

B.Tech. DEGREE EXAMINATION, DECEMBER 2008.

(Examination at the end of First Year)

Paper VI — COMPUTER PROGRAMMING

Time : Three hours

Maximum : 75 marks

Answer Question No. 1 compulsorily and ONE question from each Unit.

1. Write brief notes on :
- (a) Keywords
 - (b) Numeric constants
 - (c) Assignment operators
 - (d) Output functions
 - (e) Relational expressions
 - (f) While loop
 - (g) Continue statement
 - (h) Realloc () memory function
 - (i) Character array
 - (j) Unsized array initialization
 - (k) Pointer assignment

- (l) Printer and arrays
- (m) Union general format
- (n) Types of files
- (o) fputs ().

UNIT I

- 2. (a) Explain different operators in C language.
- (b) Write a program to find the roots of a quadratic equation.

Or

- 3. (a) Explain switch statement and give one suitable example.
- (b) Write a program for computation of electricity bill.

UNIT II

- 4. (a) Explain the looping statements in C language.
- (b) Write a program to print the Fibonacci numbers in a given range.

Or

- 5. (a) Discuss parameter passing mechanism.
- (b) Write a program to find the prime factors of a given numbers.

UNIT III

- 6. (a) Explain dynamic memory allocation of arrays.
- (b) Write a program to sort a given list of elements by using bubble sort.

Or

- 7. (a) Explain two-dimensional numeric arrays.
- (b) Write a program to reverse a given string.

UNIT IV

- 8. (a) Explain structures and unions.
- (b) Write a program to get the product of given two matrices.

Or

- 9. (a) Discuss sequential file processing.
- (b) Write a program to find a frequency count of keywords in an input program.

(DE 107)

B.Tech. DEGREE EXAMINATION, DECEMBER 2008.

(Examination at the end of First Year)

Paper VII — ENGINEERING MECHANICS

Time : Three hours

Maximum : 75 marks

Answer Question No. 1 compulsorily and ONE question from each Unit.

All questions carry equal marks.

1. (a) State Lami's Theorem. (15)
- (b) State Parallelogram law of forces.
- (c) State the conditions for equilibrium of a rigid body subjected to a system of co planar forces.
- (d) Define couple and mention any two characteristics of couple.
- (e) State parallel axis theorem.
- (f) What is radius of gyration?
- (g) What is meant by virtual work?
- (h) State D'Alemberts principle.
- (i) State Newton's second law of motion.
- (j) State principle of impulse and momentum.
- (k) Define deficit frame and redundant frame.
- (l) The angle of rotation of a body is given by the equation $\theta = 2t^3 - 5t^2 + 8t + 6$ where θ is expressed in radians and t in seconds. Determine the angular velocity when $t = 4$ seconds.
- (m) What do you understand by potential energy and kinetic energy of a body?
- (n) What is the moment of inertia of a rectangular section of width 'B' and depth 'D' about its base?
- (o) Define collinear and concurrent forces.

UNIT I

2. Determine the magnitude and direction of the resultant of the system of forces shown in the following figure. (15)

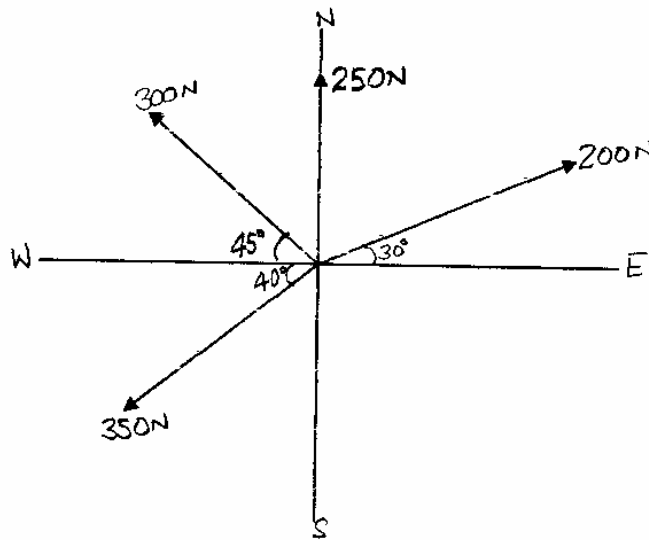

Or

3. An effort of 200 N is required just to move a certain body up an inclined plane of angle 15° , the force acting parallel to the plane. If the angle of inclination of the plane is made 20° , the effort required, again parallel to the plane, is found to be 230 N. Find the weight of the body and the coefficient of friction. (15)

UNIT II

4. Determine the centroid of the section shown in the following figure. (15)

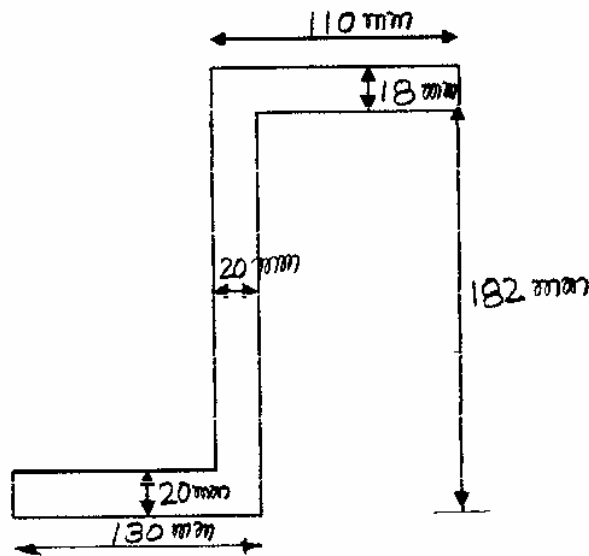

Or

5. Derive the expressions for moment of inertia of (15)
- Triangle about centroidal axis x-x parallel to the base.
 - Quarter of a circle about centroidal axis x-x parallel to base.

UNIT III

6. A uniform ladder of weight 300 N rests against a smooth vertical wall and a rough horizontal floor making an angle of 60° with the horizontal. Find the force of friction at the floor using the method of virtual work. (15)

Or

7. A stone is thrown vertically upwards with a velocity of 19.6 m/sec from the top of a tower 24.5 m high. Calculate (15)

(a) Time required for the stone to reach the ground.

(b) Velocity of the stone in its downward travel at the point in the same level as the point of projection.

(c) The maximum height to which the stone will rise in its flight.

UNIT IV

8. A bullet of mass 25 gm, moving horizontally with a velocity of 600 m/s strikes a wooden block of mass 5 kg resting on a rough horizontal surface. The bullet after striking the block remains buried in the block and both travel a distance of 90 cm, before coming to rest. Determine

(a) Average resistance between block and horizontal surface.

(b) Co-efficient of friction between block and horizontal surface. (15)

Or

9. (a) A car is traveling with a speed ' v ' on a banked track of radius ' r '. Find the angle of banking so that the reactions at the outer and inner wheels are equal.

(b) A truck of weight 20 kN is traveling at 45 kmph on a level road. It is brought to rest in 20 meter, what is the average force of resistance acting on the truck. (15)

(DE 108)

B.Tech. DEGREE EXAMINATION, DECEMBER 2008.

(Examination at the end of First Year)

Paper VIII — ENGINEERING GRAPHICS

Time : Three hours

Maximum : 75 marks

Answer any FIVE questions selecting ONE from each Unit.

All questions carry equal marks.

UNIT I

1. The distance between Tirupati and Chennai is 160 Km. A passenger train covers this distance in 4 hours. Construct a plane scale to measure the time up to a single minute. The R.F. of the scale is

1:200000. Indicate the distance covered by the train in 28 minutes.

(15)

Or

2. Construct a Hyperbola, if the distance between the foci is 100 mm and the major axis is 70 mm.
(15)

UNIT II

3. A line AB of 80 mm long is inclined to HP and VP at 40° and 30° respectively. The end A is on HP where as the end B is on VP. Draw the projections. (15)

Or

4. A pentagon of 40 mm side has one corner on HP. Its plane is inclined at 60° to VP and perpendicular to HP. Draw its projections.
(15)

UNIT III

5. A hexagonal pyramid with side of base 30 mm, axis 60 mm long has one edge of its base on VP. Its axis is inclined at 30° to VP and parallel to HP. Draw the projections of the solid.
(15)

Or

6. A hexagonal prism of side of base 40 mm and axis 75 mm long is resting on one of its rectangular faces on HP, with the axis making an angle of 30° to VP. It is cut by a section plane, perpendicular to VP, inclined at 45° to HP and passing through the mid point of the axis. Draw the sectional top view and determine the true shape of the section.
(15)

UNIT IV

7. A vertical cone of diameter of base 40 mm and height 60 mm is cut by a section plane perpendicular to VP and inclined at 30° to HP, so as to bisect the axis. Draw the development of the truncated portion of the cone.
(15)

Or

8. A vertical square prism of base 60 mm side intersected by a horizontal square prism of base 40 mm so that their axes intersect. The axis of the horizontal prism is parallel to VP and the faces of both the prisms are equally inclined to VP. Draw the projections of solid showing the lines of intersections.
(15)

UNIT V

9. Draw the isometric projection of a triangular pyramid of side of base 50 mm and height 80 mm, when it is resting on HP such that an edge of the base is parallel to VP.

(15)

Or

10. Draw the top view, front view and right side view of the block shown below.

(15)

